

Series PBA Precision Resistor

Applications:

- Power modules
 - Frequency converters
 - Switch mode power supplies
-
- Up to 10 W permanent power
 - 4-terminal connection
 - Pulse power rating 2 J for 10 ms
 - Excellent long-term stability
 - RoHS 2011/65/EU compliant

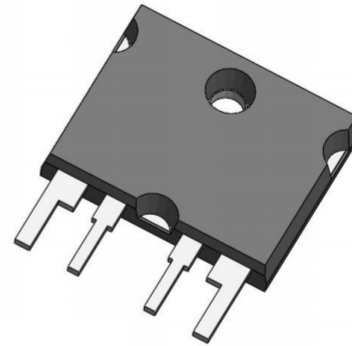

Product Detail:

1. Derating

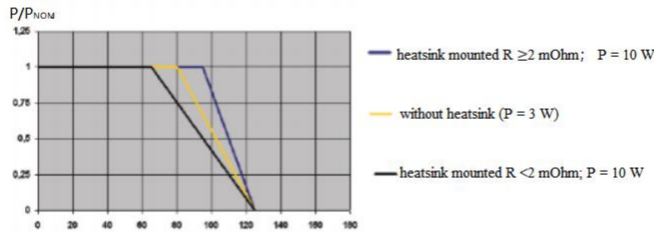

2. Dimensions in millimeters

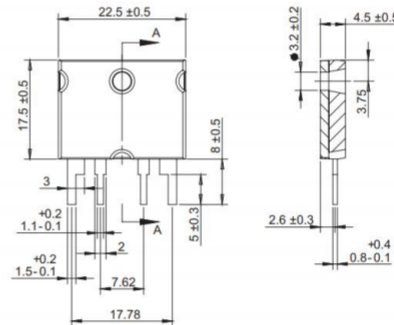

3. Maximum pulse energy respectively pulse power for continuous operation

